

3-PRSTNO PARALELNO PRIJEMALO HDQ / 3-FINGERED PARALLEL GRIPPER HDQ

Tehnični podatki / Technical data

Medij Fluid	filtriran, suh ali naoljen komprimiran zrak filtered, dry or oiled compressed air
Delovni tlak Working pressure	3–7 bar
Temperatura Temperature	max. +60 °C

Material	
Telo / Body	Aluminij, jeklo / Aluminium, steel
Prsti / Fingers	jeklo / steel
Tesnila / Seals	NBR



i Senzorji SMO40TP stran 39
Sensors SMO40TP page 39

PRIMER NAROČANJA / HOW TO ORDER

Nazivna velikost / Size _____
25, 32, 40, 50, 63

HDQ -

Tip Type	Ø Cil Ø Cyl [mm]	Ø D5 Zapr Closed [mm]	Ø D6 Odprt Open [mm]	Sila stiska Clamping force (N/5 bar/prst/finger)	
				Notranji / Internal diameter	Zunanji / Outer diameter
HDQ25	25	20	26	30	35
HDQ32	32	20	28	70	82
HDQ40	40	24	32	131	149
HDQ50	50	26	38	282	314
HDQ63	63	35	51	446	496

i Prsti prijemala in njihova vodila so izdelana iz jekla. Prsti so vlezajeni v tutorih kar temu prijemalu zagotavlja dolgo življensko dobo z minimalno zračnostjo ter veliko togostjo za prijemanje in manipulacijo različnih kosov. Fingers and fingers guides are made from steel. Fingers are beared in tslots, which guarantees durability along with minimum clearance and great stiffness for gripping and manipulation of various pieces.

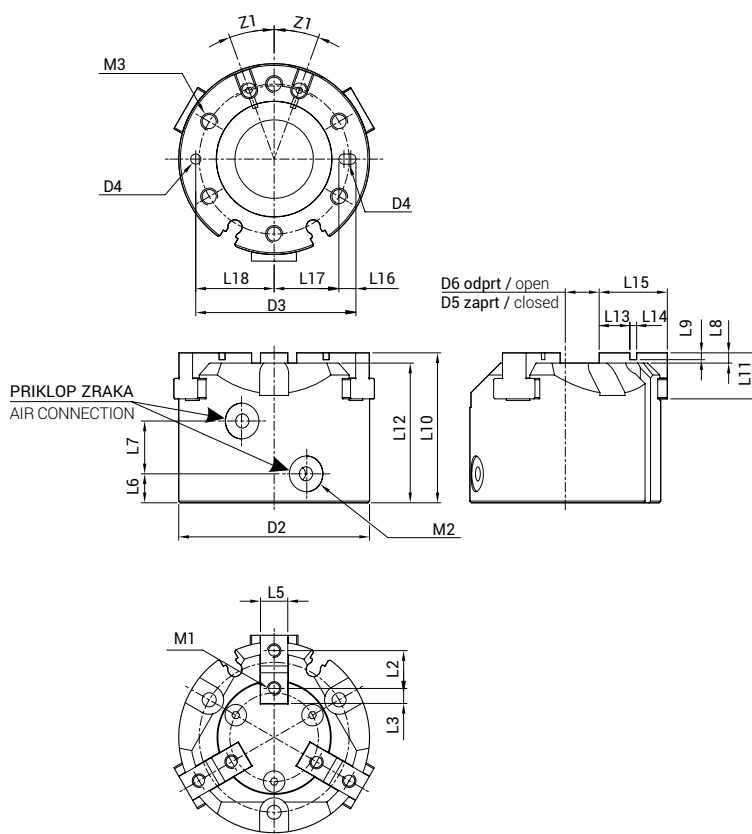

Tip Type	L2	L3	L5	L6	L7	L8	L9	L10	L11	L12	L13	L14	L15	L16	L17	L18	RD2	RD3	RD4	M1	M2	M3	Z1°	m [kg]
25	8	3	6	7,5	14	3	2	40	12	37	6	2	14	5	14,5	17	42	36,5	3	M3	M5	M4	20	0,15
32	11	4,5	8	9,5	15,5	3	2	44	13,5	41	9	2	20	5	19	23	56	47	3	M4	M5	M5	20	0,30
40	12	4,5	8	10	14	3	2	47	15	44	9	3	21	6	23,5	26,5	62	56	4	M4	M5	M6	20	0,38
50	14	5	10	10	18	3	2	55	17,5	52	10	4	24	6	28	31	70	65	4	M5	M5	M6	20	0,56
63	17	5,5	12	12	22	4	3	66	22	62	11	6	28	7	34,5	38	86	79,5	5	M5	M5	M6	-	1,03